

Item No.	HZ	P [kW]	Ptotal [kW]	Gas connection [inch]	Gas family
GMHB	2	12.8	25.6	R3/4"	2H+3B/P (natural gas and LPG)
GMHB8M	2	10.0	20.0	R3/4"	1a (G110: 8 mbar city gas, used in Stockholm/ Copenhagen)

Verwendungsbereich 740x750x1000	Toleranz nach DIN ISO 2768-mK	Oberflächen DIN ISO 1302	Maßstab: 1:16 Werkstoff 1.4301	Gewicht: 154.83 kg
Name	Datum	Gas Lavastone-Grill KOS		
Bearb. M.B.	21.07.2023			
HEIDEBRENNER		GMHB		A3

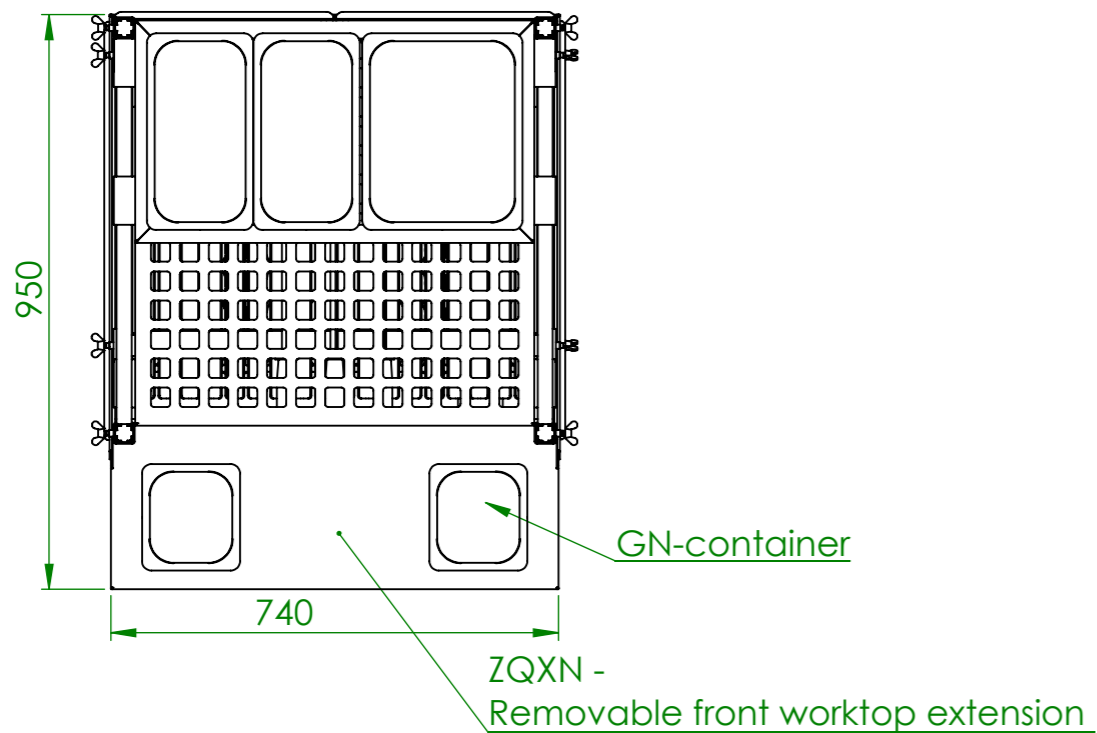
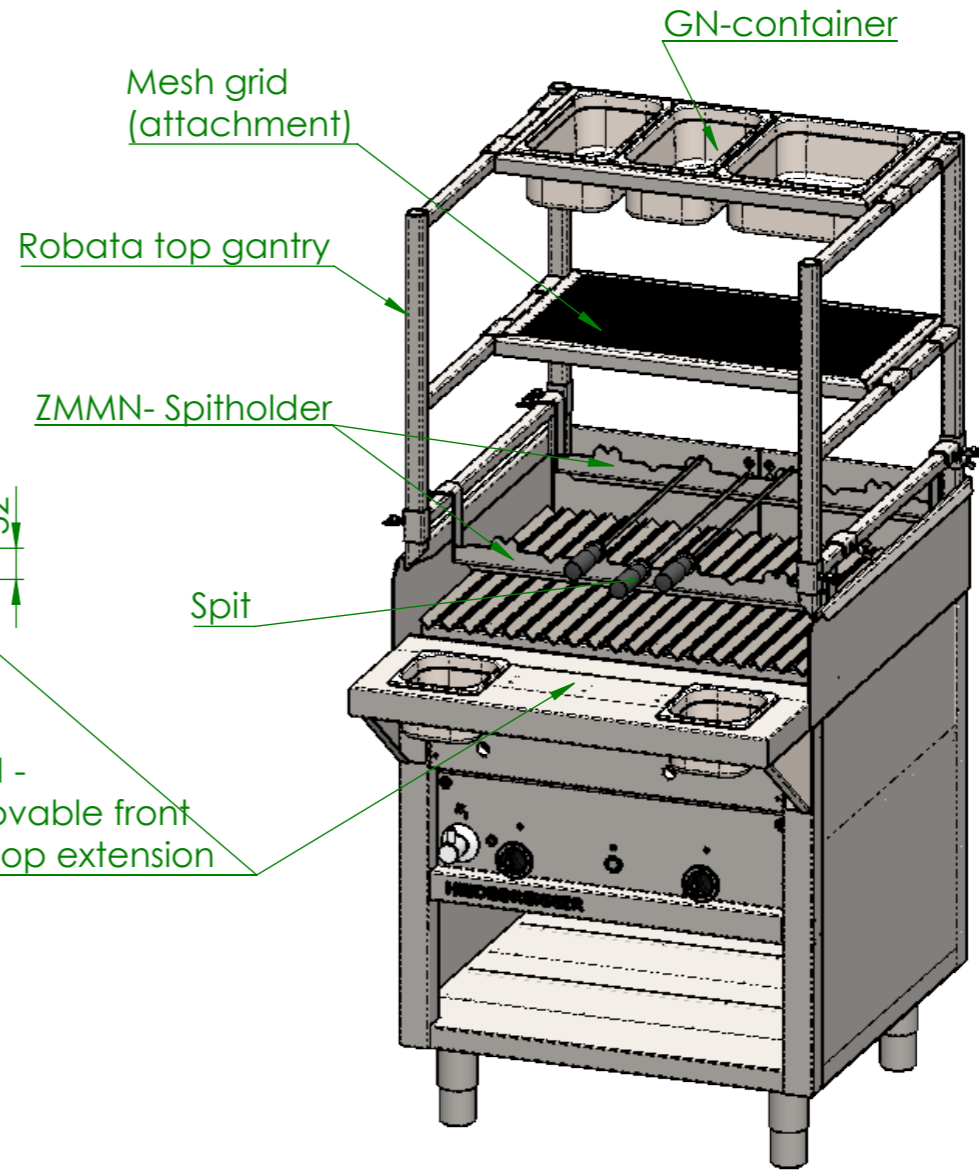
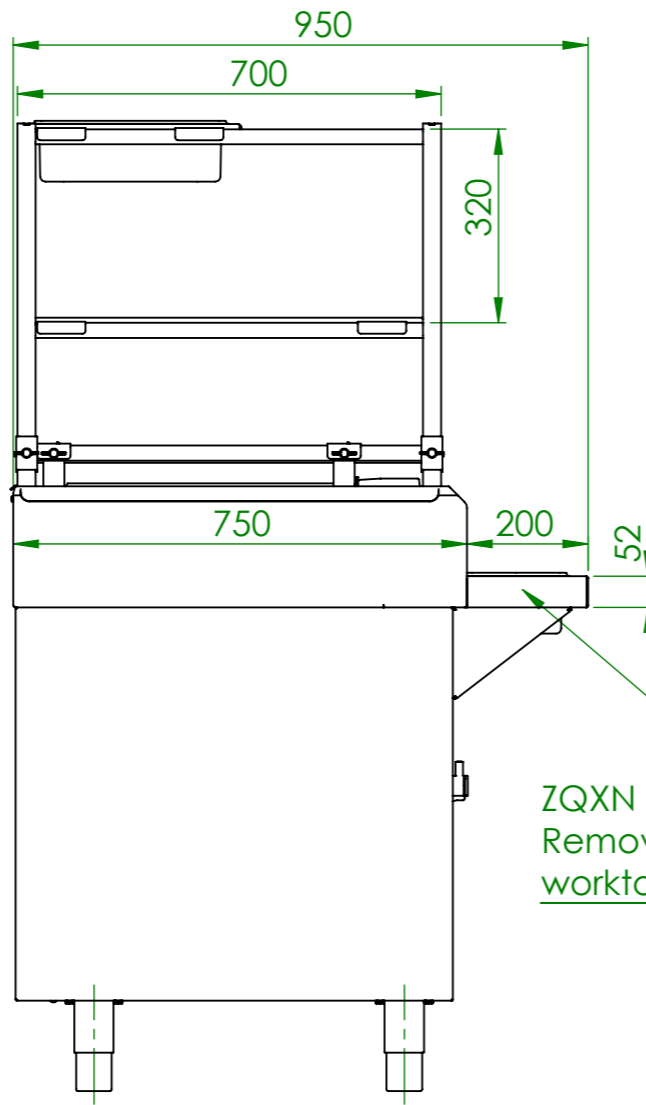
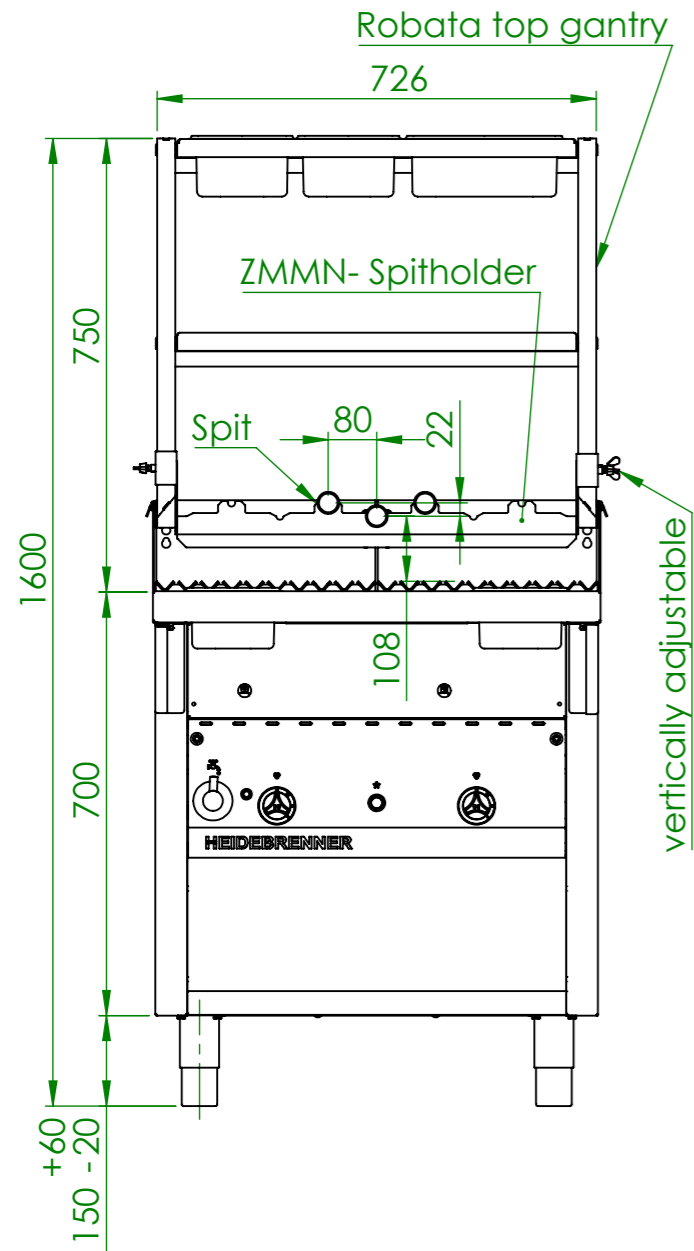

Verwendungsbereich 740x950x1600	Toleranz nach DIN ISO 2768-mK	Oberflächen DIN ISO 1302	Maßstab: 1:12.5 Werkstoff 1.4301 AISI 304	Gewicht: 188.51 kg
Name	Datum	Gas Lavastone-Grill KOS		
Bearb. M.B.	21.07.2023			
HEIDEBRENNER		GMHB+Etagere+GN_keeper		A3