

A  
B  
C  
D  
E  
f

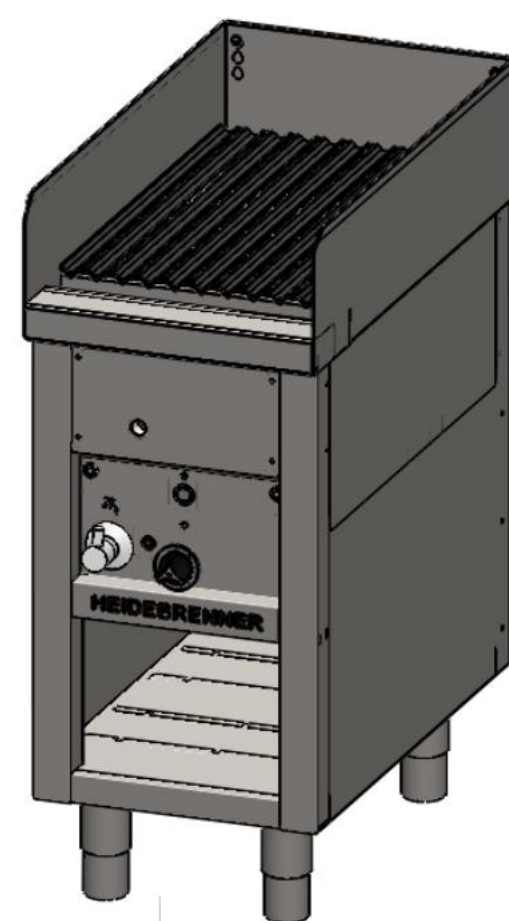
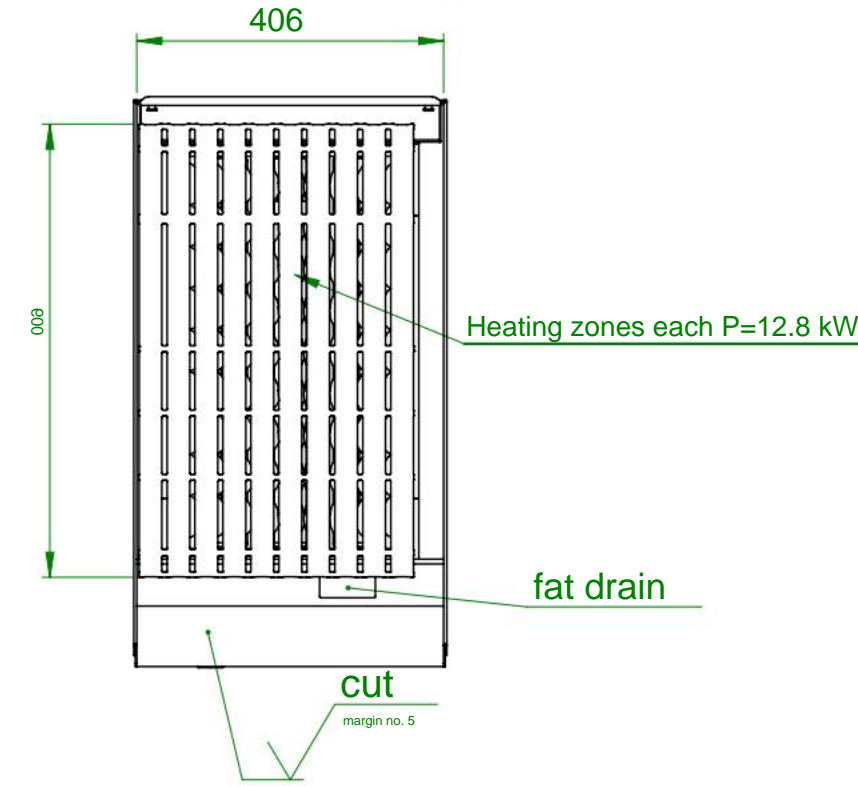
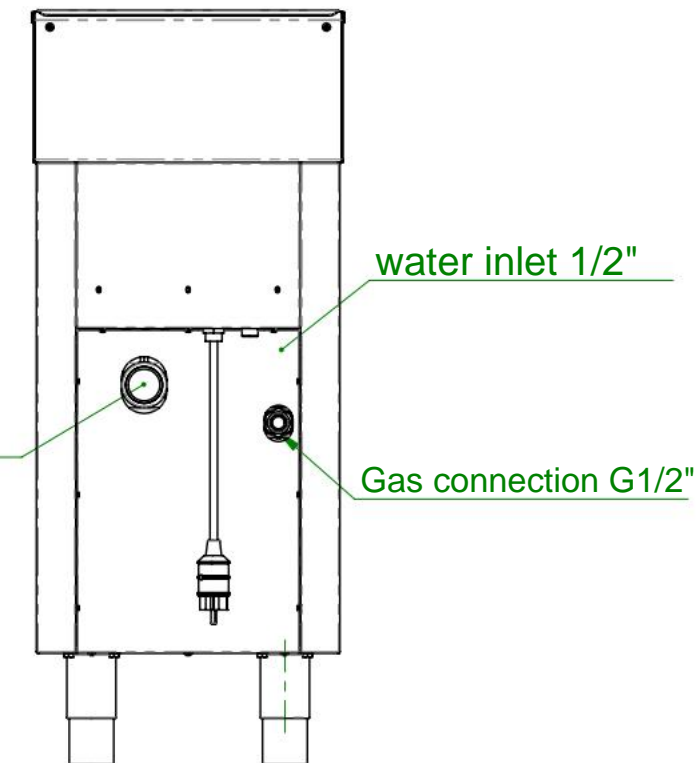
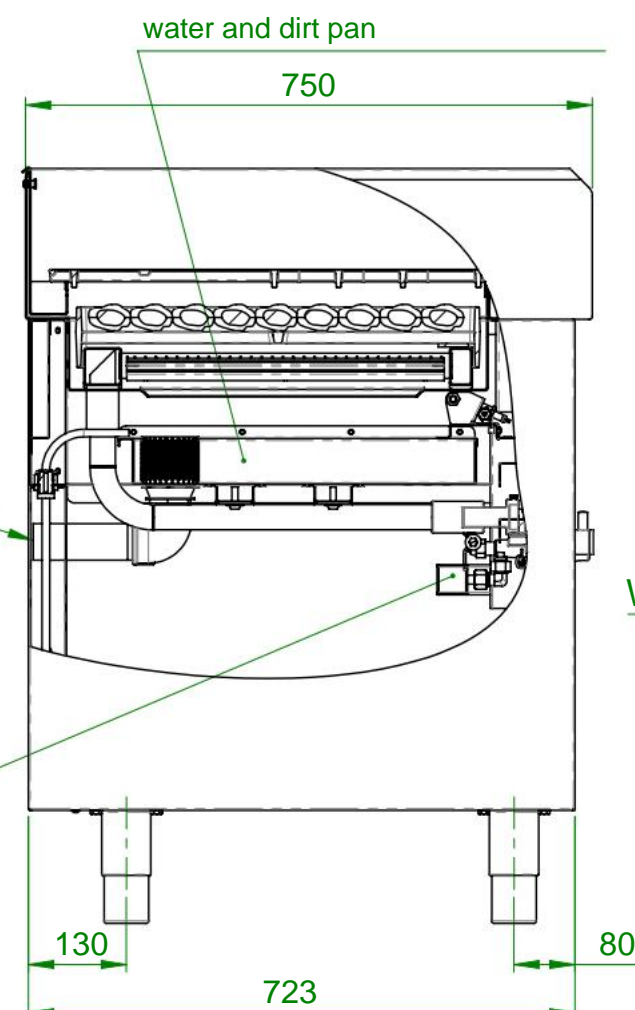
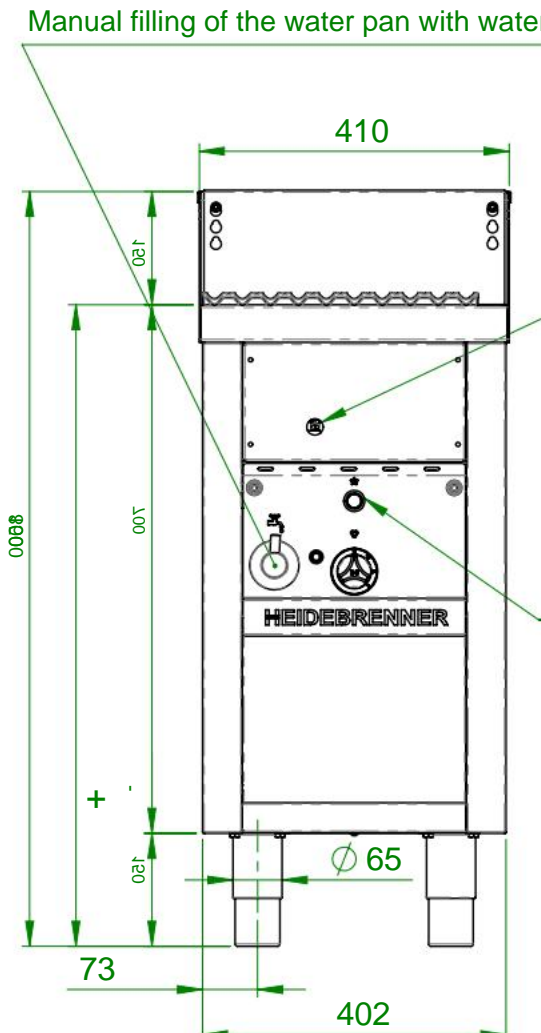

area of use	tolerance after	surfaces	Scale:	1:10	Weight:	94.07kg
410x1000x750	DIN ISO 2768-mK	ISO 1302	material	1.4301		
Surname		Date		Gas lava stone grill FILICUDI		
edit MB		07/16/2020				
HEIDEBRENNER			GMHA		A3	

Article No.	HZ	P [kW]	Pges [kW]	Volume flow V [m3/h]	gas connection [Customs service]	Length of consumption line [m] delta p=0.6mBar
GMHA 1	12.8	12.8		1.35	1/2"	6

2 3 4

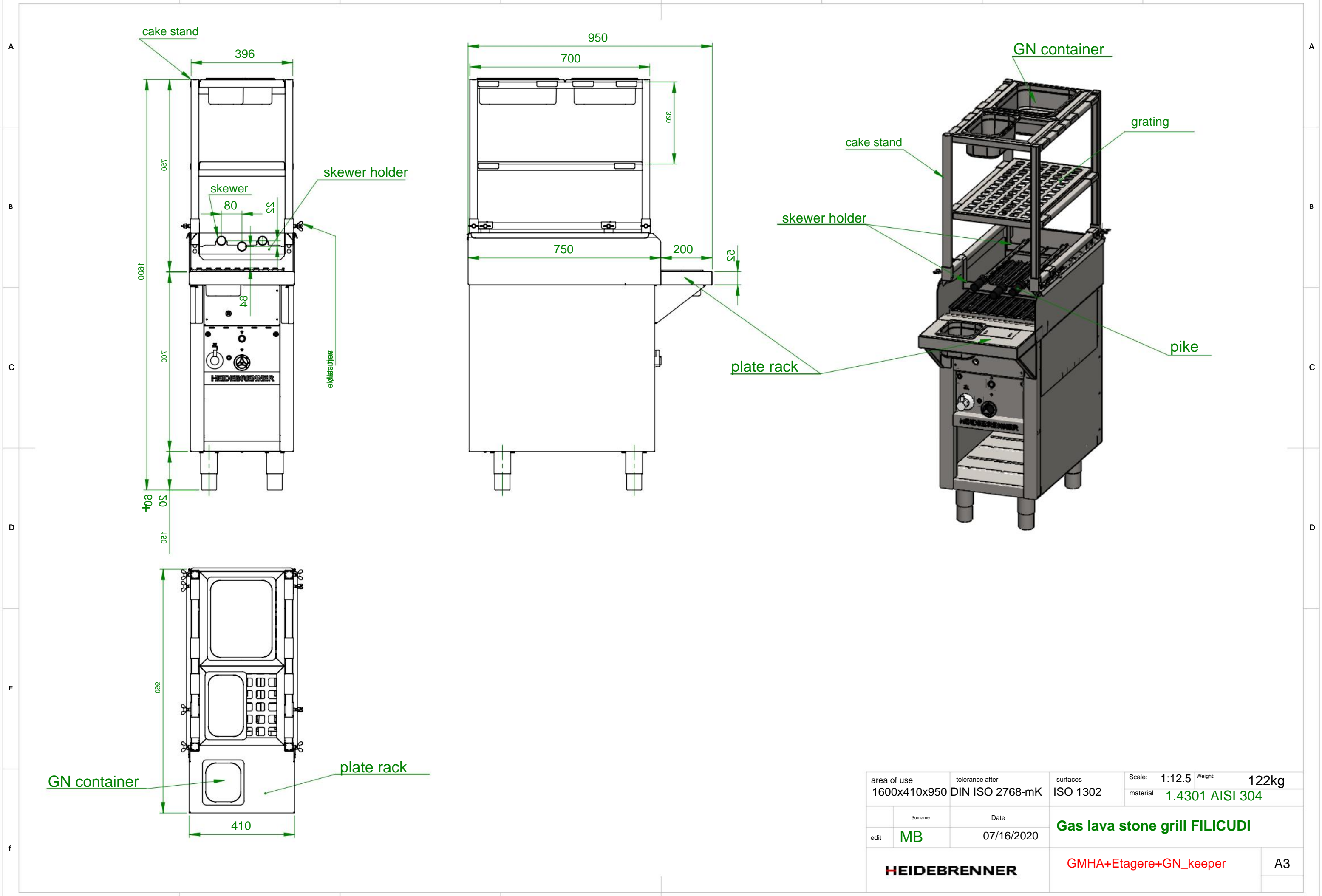

area of use	tolerance after	surfaces	Scale: 1:12.5	Weight: 122kg
1600x410x950	DIN ISO 2768-mK	ISO 1302	material	1.4301 AISI 304
edit	Surname	Date	<b>Gas lava stone grill FILICUDI</b>	
	MB	07/16/2020	<b>GMHA+Etagere+GN_keeper</b>	
<b>HEIDEBRENNER</b>			A3	