

2 3 4 5 6 7

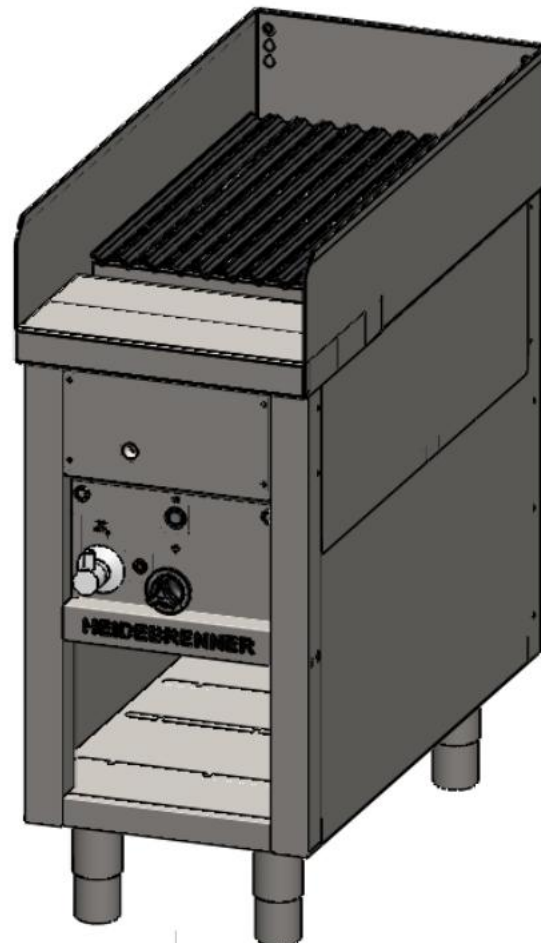
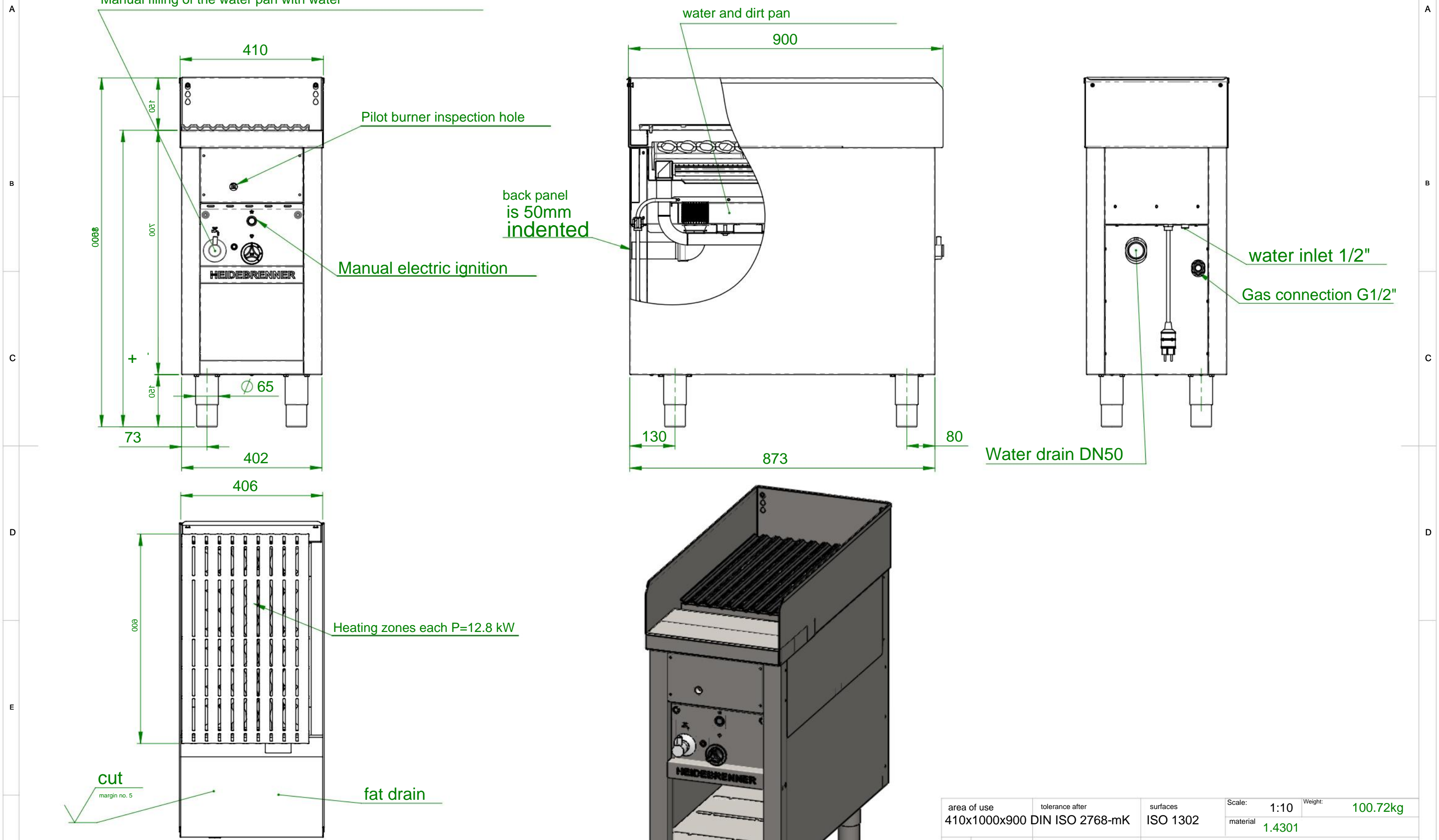

Article No.	HZ	P Pges [kW]	Volume flow V [m3/h]	gas connection [Customs service]	Length of consumption line [m] delta p=0.6mBar
GMKA 1	12.8	12.8	1.35	1/2"	6

area of use	tolerance after	surfaces	Scale: 1:10	Weight: 100.72kg
410x1000x900	DIN ISO 2768-mK	ISO 1302	material 1.4301	
Surname	Date	Gas lava stone grill FILICUDI		
edit MB	07/14/2020			
<b>HEIDEBRENNER</b>		<b>GMKA</b>		A3

A  
B  
C  
D  
E  
f

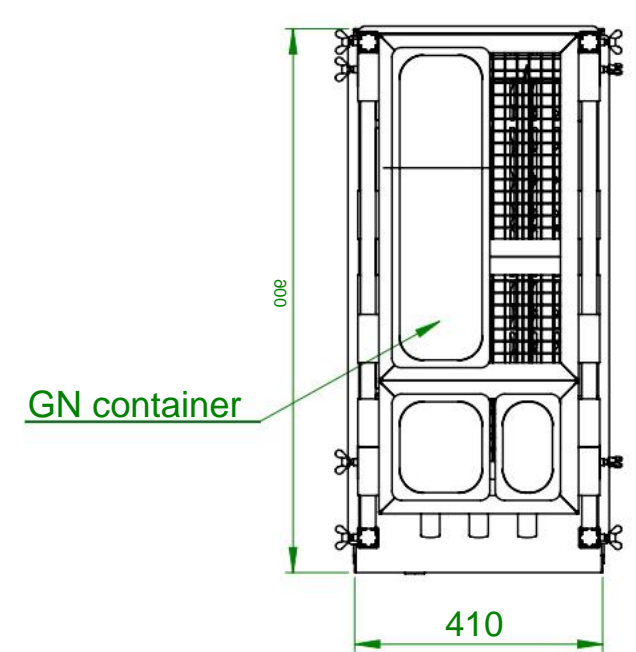
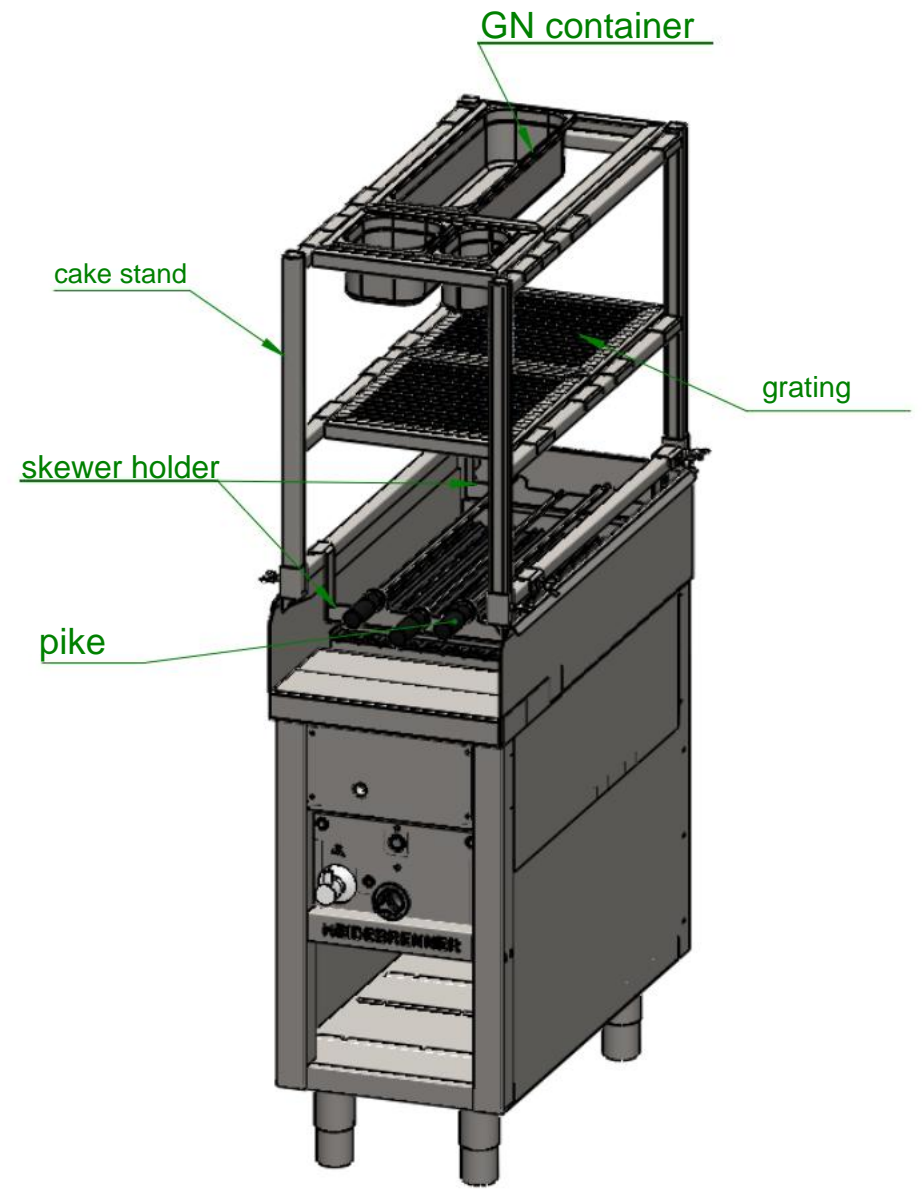
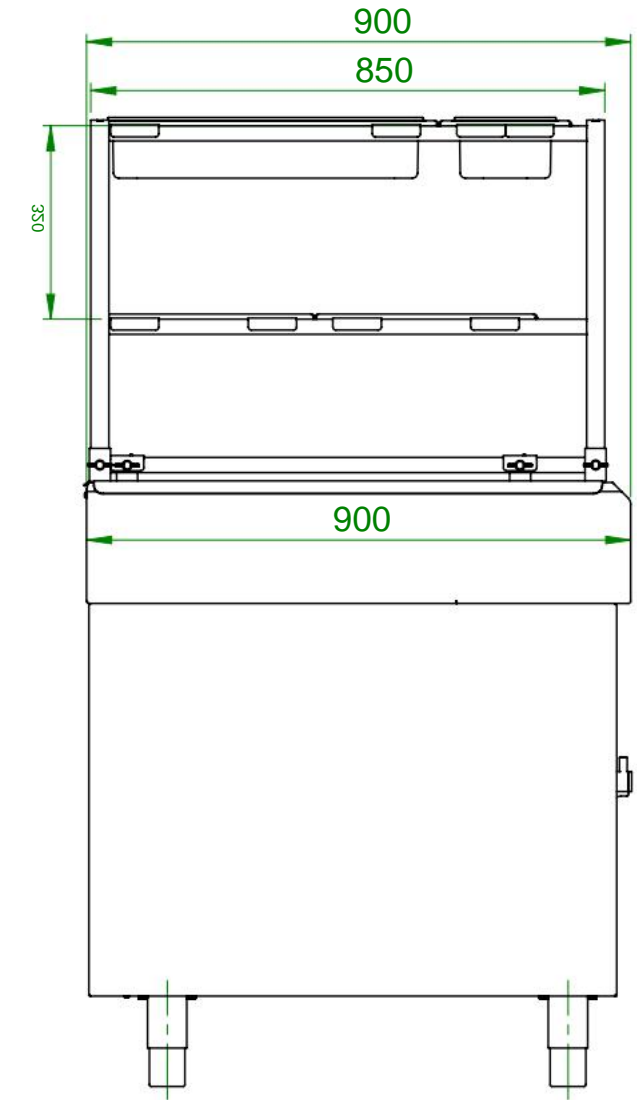
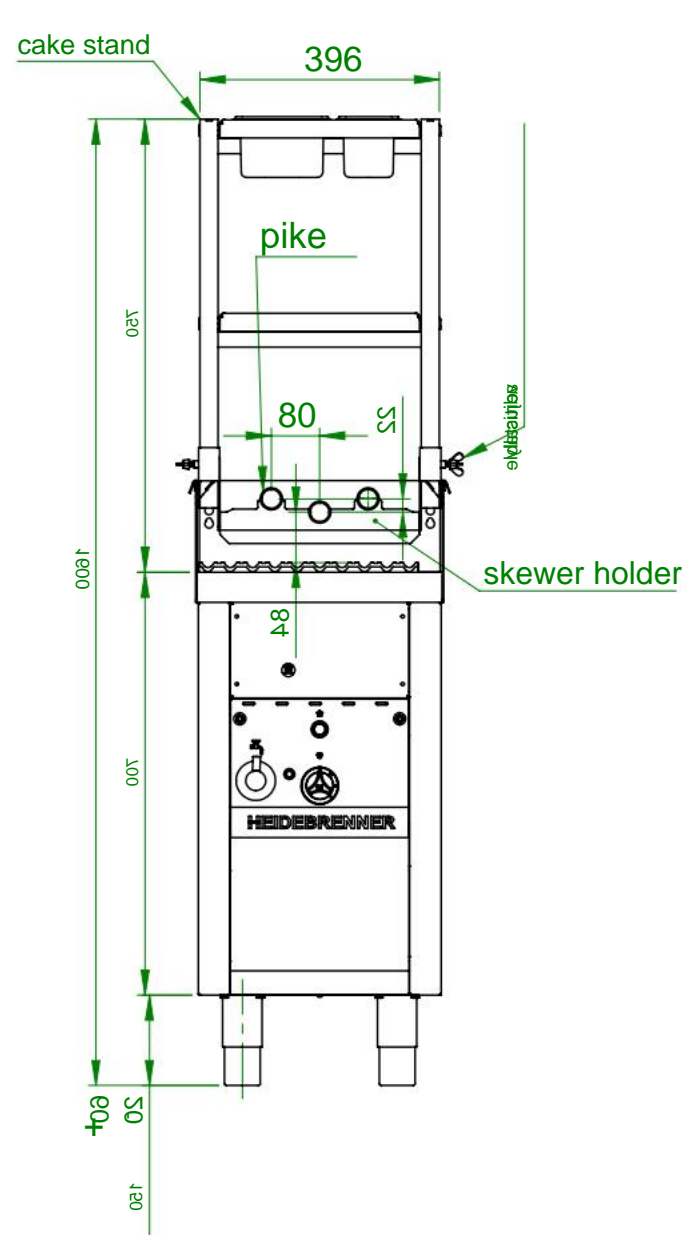

area of use 410x1600x900	tolerance after DIN ISO 2768-mK	surfaces ISO 1302	Scale: 1:12.5	Weight: 132kg
			material 1.4301 AISI 304	
edit MB	Surname	Date	Gas lava stone grill FILICUDI	
		07/14/2020		
HEIDEBRENNER		GMKA+Etagere+GN_keeper		A3