

BACKMASTER EB 30^{MT}

3 X BN43

Air circulation, electric, left hinged, water connection



HIGHLIGHTS

MT-TECHNOLOGY:

- 5" MultiTouch Display
- Climatic® MT
- Last®20
- Quick Set
- Multi Baking
- Quick Mode/-ASC with password manager
- Weekly programming
- Automatic door release
- Baking with safety and system
- Guaranteed efficiency
- Large viewing window with ideal lighting
- Multi Connect
- Plug & Play

Eloma GmbH | Otto-Hahn-Str. 10 | 82216 Maisach/Germany

BACKMASTER EB 30^{MT} - 3 x BN43

DIMENSIONS

Width x depth x height in mm: 600 x 605 x 530

Weight: 48 kg

Weight with packaging: 66 kg

Number levels: 3 x 440 x 350 mm

Distance between levels: 85 mm

ELECTRICAL SUPPLY

Voltage: 230V/1 N AC [400V/ 3N AC]

Connection load: 3.60 kW [5.3 kW]

Rated current: 15.0 Amp [6.3 Amp]

Protection: 1 x 16 Amp [3 x 10 Amp]

Res. current circuit breaker: Type B

Recommended cross section: 2.5 qmm

Noise emission: < 70 dB (A)

Article number: EL3013002-2A [EL3013006-2A]

SAFETY CLEARANCE

Rear: min. 50mm

Right: min. 50mm

Left: min. 50mm

Minimum distance to heat sources: min. 50mm

LOADING CAPACITY

Baking chamber volume: 50 l

3 x BN43

WATER CONNECTION

Water supply/dim: 1 x G 3/4" A

Flow pressure: 2 - 6 bar (200 - 600 kPa)

WATER QUALITY

General requirement: drinking water

Total hardness: $\leq 3^{\circ}\text{dh} / 70 - 125 \text{ ppm} / 7-13^{\circ} \text{ TH} / 5-9^{\circ} \text{e}$

pH-Wert: 7.0 - 8.5

Cl (chloride): max. 60 mg/l

Cl₂ (free chlorine): max. 0.2 mg/l

SO₄²⁻ (sulphate): max. 150 mg/l

Fe (iron): max. 0.1 mg/l

Temperature: max. 40°C

Electrical conductivity: min. 20 μ S/cm

WATER CONSUMPTION

Drinking water: in accordance with the steaming setting

Max. flow rate: 25 l/h (at 4 bar)

HEAT EMISSION

Latent: 2.33 MJ/h, sensitive: 1.56 MJ/h

STANDARDS

Safety: CE-Conformity

Protection: IPX 4

Built according to: DIN 18866-2



BACKMASTER EB 30^{MT} - 3 x BN43

STANDARD FEATURES

400 program spaces/20 steps each
Acoustic signal adjustable
Active dehumidification
Additional baking time
Automatic daylight-saving time
Automatic door release following the baking program end
Automatic resting time
Cleaning semi-automatic
Compensation of cooking time in Multi Baking
Control panel with MultiTouch-display
Door lock: Electrical door lock
Door with halogen lighting and double glazing
Fan wheel autoreverse
Fan wheel pulsed
Favourites list
Favourites marking and filtering
HACCP data logging and display
Half loading function
Hygienic, large baking chamber with rounded corners
Individualisation of operating concept with password manager
Input alphanumeric
Integration of (own) images
Integration of (own) sounds

Manual steaming
Memory Function
MT-Technology: <ul style="list-style-type: none">• Baking mode• Climatic® MT• Last®20• Multi Baking• MultiTouch-Display• Quick Mode baking• Quick Set
Multi-lingual control panel
Preheat/Cooldown function adjustable
Pre-set of steam injection (in 10 ml steps)
Program information input on the unit
Program list (alphabetical)
Repeat Mode
Selectable starting screen
Steam injection adjustable in millilitres or seconds
Steptronic®
Temperature setting 30°C - 250°C
Timer function: Entry of starting and ending time
USB Interface
Water resistance IP X4
Weekly programming for baking programs

OPTIONS

Design Kit red control panel
Energy optimisation interface
LAN Interface
Right hinged
Water tank

ACCESSORIES

Combimix kit, support stands and condensation hoods for mix-stations
Hanging rack with 4 levels
Multi-Eco condensation hood
ProConnect
Support stands
Trays and grids



BACKMASTER EB 30^{MT} - 3 x BN43

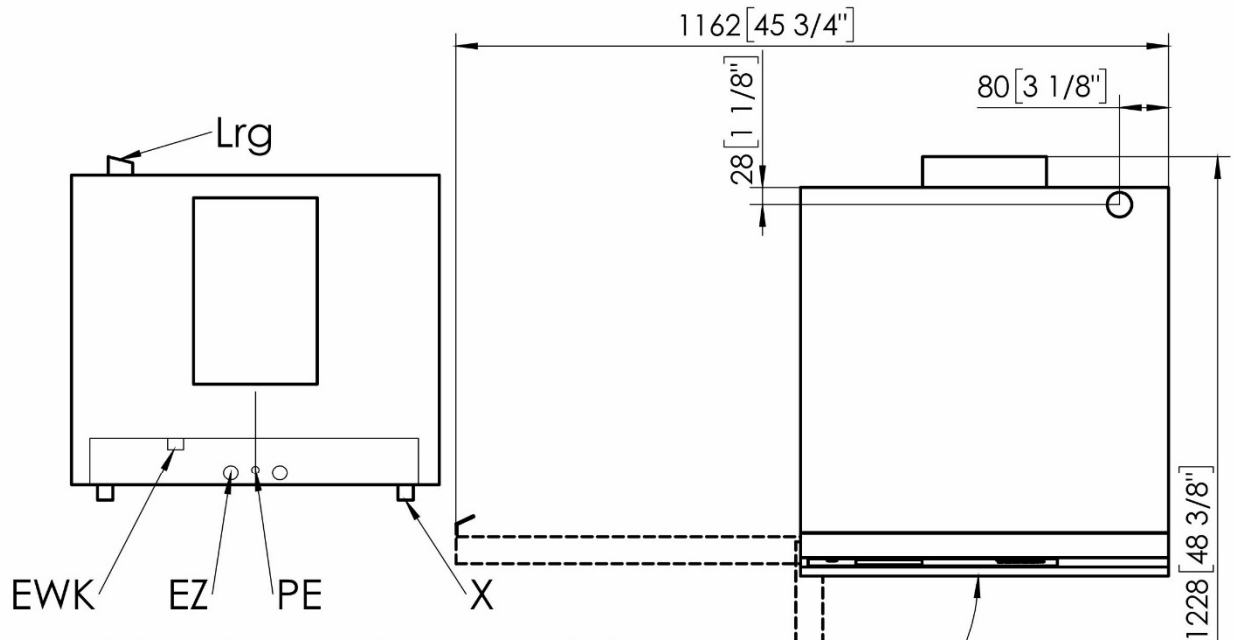
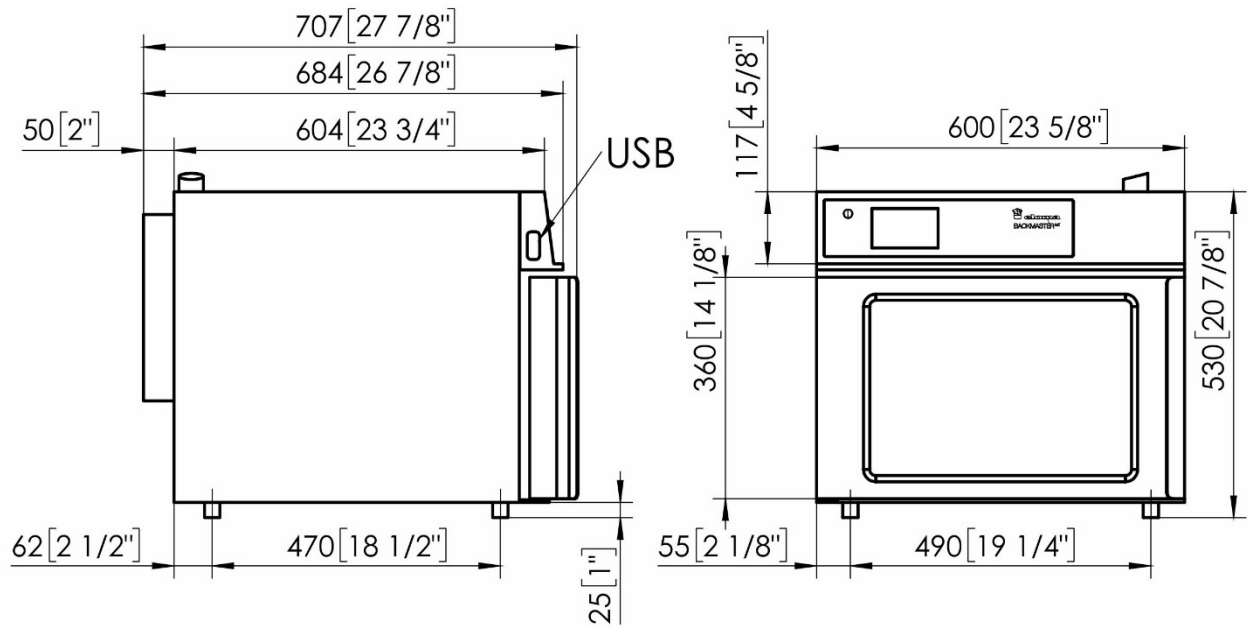

- Lrg Abluftrohr / Exhaust air pipe / Ventilation
- EWk Anschluss Weichwasser (G3/4")
Connection for soft water (BSP3/4")
Eau adoucie froide (G3/4")
- EZ Stromversorgung / Power supply /
alimentation de potentiel
- PE Anschluss Potenzialausgleich
Connection for potential equalisation
Compensation de potentiel
- X FüÙe, justierbar (+/- 10mm)
Feet, adjustable (+/- 3/8")
- USB USB-Buchse / USB port



an Ali Group Company



The Spirit of Excellence