

BACKMASTER

SIZES: EB 30 ^{MT}, EB 30 XL ^{MT}

ENERGY TYPE: ELECTRIC

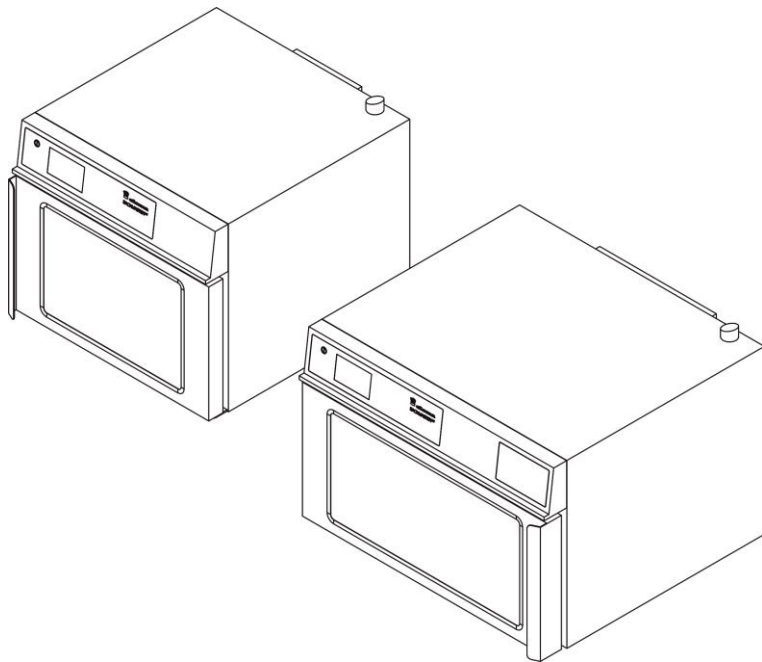

Translation of the original installation instructions

Subject to technical changes.
Read carefully before use.
Keep safe for future use.

LEGAL NOTICE

You have chosen an Eloma Backmaster EB 30^{MT} or EB 30 XL^{MT}. Many thanks for your trust. Please read the initialisation instructions all the way through before commissioning, and pay particular attention to the safety notes.

Eloma GmbH – A gut decision
Otto-Hahn-Str. 10
82216 Maisach
Germany

Tel. +49 (0) 8141 395-0
Fax +49 (0) 8141 395-130

Visit our website www.eloma.com for user tips and recipes
Please also feel free to contact our application advice department:
Tel. +49 (0) 8141 395-150
E-mail application@eloma.com

You can contact us almost 24 hours a day, 7 days a week, 365 days a year:
Tel. +49 (0) 8141 395-188
E-mail service@eloma.com

Our Customer Service department will be happy to help you with any question on our products:
Tel. +49 (0) 35023 63-888
E-mail sales@eloma.com

Please refer to the terms and conditions (T&Cs) on our website for information on liability for material defects and the warranty.



Device type:

Device no.:

Dealer:

Installation technician:

Date:

Installed on:

TABLE OF CONTENTS

1	About this document	5
1.1	Content and target group	5
1.2	How to use this document	6
1.3	Warranty and limitation of liability	6
1.4	Structure of warnings and the symbols used	7
1.5	Overview of the device signs used	8
1.6	Use of figures	9
1.7	Variants and device sizes	9
2	Safety	10
2.1	Qualifications of installation staff	10
2.2	Safety notes	11
3	Planning installation	14
3.1	Device data	14
3.2	Requirements for the location for installation	15
3.3	Data for device connection	17
3.4	Connection data	18
4	Transporting and unpacking the Backmaster	20
4.1	Transporting the Backmaster with a lift truck	20
4.2	Unpacking the device and accessories	20
5	Setting up the Backmaster	21
5.1	General set-up instructions (summary)	21
6	Connecting the Backmaster	23
6.1	Supply water connection	23
6.2	Electrical connection	25
6.3	Door latch, emergency release	26

Table of contents

7	Disposal and environmental protection	27
8	Appendices	28
8.1	Dimensional drawings	28
9	Maintenance comments / notes	36

1 ABOUT THIS DOCUMENT

1.1 CONTENT AND TARGET GROUP

These installation instructions describe how to Backmaster is safely transported, set up and installed. The installation instructions are intended for persons who transport, set up and install the device with the following occupational field and area of responsibility:

Occupational field	Area of responsibility
Installation technician - electrics	Connection to the local electrical power supply
Installation technician - water	Connection to local water and waste water lines
Commissioning technician/ service technician	Overall responsibility for correct set-up, installation and commissioning of the Backmaster Detailed operator and user training
Operating company or party responsible for the device at the operating company	Proper in-house storage and proper transportation of the device before installation Knowledge of the safety-related functions and devices Passing on of the knowledge on device operation to the operator

Tab. 1: Responsibilities, fields of activities and tasks

1.2 HOW TO USE THIS DOCUMENT

The translation of the original installation instructions is always included in the scope of delivery of the device and must comply with the following guidelines:

- ▶ Keep the installation instructions so that they are accessible for installation staff.
- ▶ Staff with responsibility for installation must have read or been informed and trained on the installation instructions, in particular the section "Safety notes", before starting work.
- ▶ These installation instructions must be kept safe during the service life of the device and must be handed over to the next owner in case of a change in ownership. Otherwise, a new copy will need to be ordered from the manufacturer or supplier.
- ▶ Every update or supplement published by the manufacturer must be added to the installation instructions.
- ▶ These installation instructions include a circuit diagram of the Backmaster. The circuit diagram is enclosed with this device. In the case of table-top devices the circuit diagram can be found in the installation space. Make sure that the circuit diagram is kept safe in the installation space at all times.

1.3 WARRANTY AND LIMITATION OF LIABILITY

The device must not be modified technically, e.g. constructional conversion, without the approval of the manufacturer/supplier. Any warranty or guarantee cover will be rendered null and void in case of unauthorised technical modifications. Furthermore, the safety of the device is no longer assured. Warranty or liability claims for personal injury or material damage cannot be asserted if caused by one or more of the following causes:

- Improper use of the baking device.
- Improper commissioning, improper operation or incorrect maintenance of the device.
- Faults which are caused by failure to adhere to these installation and operating instructions.





You will find detailed information on liability for material defects and the warranty in our general terms and conditions.

1.4 STRUCTURE OF WARNINGS AND THE SYMBOLS USED

Symbol	Explanation
	Warning: This symbol is followed by a warning
1.	Instruction for action with multiple steps: Multiple instructions for actions have to be carried out in the stipulated order.
2.	
	Single-step instruction for action: Precisely one instruction for action has to be carried out.
	List of multiple single-step instructions for actions: Instructions for actions can be carried out in any order.

Tab. 2: Explanation of the notes used







The meanings of the pictograms and signal words used are shown in following table:

Symbol	Explanation
	DANGER! Type and source of hazard. Consequence: Failure to observe will lead to fatal injury. ▶ Measure to prevent the hazard.
	WARNING! Type and source of hazard. Consequence: Failure to observe will lead to serious injuries. ▶ Measure to prevent the hazard.
	CAUTION! Type and source of hazard. Consequence: Failure to observe will lead to minor injuries. ▶ Measure to prevent the hazard.
	NOTE Type and source of hazard. Consequence: Failure to observe will lead to material damage. ▶ Measure to prevent the hazard.
	INFORMATION: Tip on operation.

Tab. 3: Explanation of the symbols and signal words used

1.5 OVERVIEW OF THE DEVICE SIGNS USED

Warning and information signs with the following meanings are attached to all Backmasters EB 30^{MT} / EB 30 XL^{MT} where they are clearly visible:

Sign	Meaning
	DANGER! "Dangerous electrical voltage!"
	WARNING! "Hot surface up to 150 °C!"
	WARNING! "Hot fluids in insert containers!"
	DANGER! "Risk of fire"
	WARNING! "Hot steam can be expelled!"
	MARKING "Equipotential bonding connection"
 Name _____ Unterschrift _____	MARKING "Completed device testing and quality control!"

Tab. 4: Overview of the device signs used

1.6 USE OF FIGURES

Figures are shown as examples and may differ from the supplied baking device.

1.7 VARIANTS AND DEVICE SIZES

There are two versions of the Backmaster EB 30^{MT}:

Designation	Version
EB 30 ^{MT}	3 inserts 440 x 350 mm
EB 30 XL ^{MT}	3 inserts 600 x 400 mm

Tab. 5: Overview of device sizes and versions

2 SAFETY

All Eloma devices comply with the relevant safety standards but not all residual risks can be ruled out.

2.1 QUALIFICATIONS OF INSTALLATION STAFF

The installation staff must be familiar with and adhere to the respective valid regional regulations when installing the device. **The standards and regulations which are referenced, are valid in Germany.**

The following conditions have to be adhered to:

- ▶ The device must be installed by an Eloma service partner.
- ▶ Make sure that the device is only put into operation by persons who have read the installation instructions and the operating instructions for the device carefully and in full, and understood the safety notes.
- ▶ Make sure that the water connection is only established by approved and authorised specialist staff.
- ▶ Make sure that the electrical connection is only established by an authorised electrical installation technician.
- ▶ Valid regional and local regulations, the regulations of the VDE and regulations of the energy supply company must be adhered to.

2.2 SAFETY NOTES

2.2.1 IMPROPER INSTALLATION



CAUTION!

Risk of injury and material damage from improper installation!

- ▶ Only perform installation in accordance with these installation instructions.
- ▶ Do not convert or modify the devices.
- ▶ Do not open the housing.

2.2.2 TRANSPORTATION



CAUTION!

Risk of injury and material damage from improper transportation!

- ▶ Do not stack the devices on a pallet.
- ▶ Secure the devices on the pallet to prevent it from falling off.



CAUTION!

Risk of devices on castors toppling and making uncontrolled movements as a result through uneven floor!

- ▶ Only transport the devices on an even floor (max. 10° inclination).
- ▶ Move the devices carefully.
- ▶ Secure the castors on the device using the brake.

2.2.3 SETTING UP



CAUTION!

Risk of injury and material damage from improper set-up!

- ▶ The device must be set up by at least two persons.
- ▶ Only stack devices which are designed for stacking.
- ▶ For stacked devices:
 - Use stacking frames wherever possible.
 - Secure the devices to prevent them from falling.

2.2.4 ELECTRICAL CONNECTION



DANGER!

Electric shock from live parts!

- ▶ Make sure that only sufficiently qualified specialists install the electrical connection.
- ▶ Adhere to the data on the Backmaster's type plate.
- ▶ Replace a damaged electrical cable immediately. Do not connect devices with a damaged electrical cable.
- ▶ Lay lines (in particular on devices on castors) so that the lines cannot become damaged.
- ▶ Do not connect the device if you suspect damage on the device.



DANGER!

Electric shock as a result of residual charges in components which store a charge!

- ▶ Make sure that components which store a charge (e.g. frequency converters, capacitors etc.) are always discharged when working inside the device.

2.2.5 WATER CONNECTION



CAUTION!

Water damage due to improper installation of the water connection!

- ▶ Make sure that only sufficiently qualified specialists install the water connection.
- ▶ Adhere to the data on the device's type plate.
- ▶ Lay lines (in particular on devices on castors) so that the lines cannot become damaged.
- ▶ Do not connect the device if you suspect damage on the device.
- ▶ Install a return flow inhibitor as per EN 13959, design EA, in the operating company's drinking water installation upstream of the device.
- ▶ For UK: Installation requirements as per WRAS conformity: The use of WRAS-approved return flow inhibitors of types CA, EC, ED or an AG air gap for the supply connection is provided.

2.2.6 DEVICE WITH WATER TANK (OPTIONAL)



CAUTION!

Do not insert the water tank into the device without a closed cover! Only top up with soft water!

- ▶ The supplied water must have a chlorine and sulphate content of less than 50 mg/l (see limit values for supply water).
- ▶ If possible, only top up the quantity of water that is required for one day (max. 2.1 l).
- ▶ Make sure that no dirt gets into the water tank.

3 PLANNING INSTALLATION

3.1 DEVICE DATA

Data	EB 30 ^{MT}	EB 30 XL ^{MT}
Housing	Stainless steel version	
Device dimensions [mm]		
Width	600	760
Depth	635	665
Height	530	530
Number of inserts	3 x 440 x 350 mm	3 x 600 x 400 mm
Insert spacing [mm]	85	
Baking chamber temperature	30 °C - 250 °C	
Weight [kg]	50	60
Packaging [kg]	16	16
Maximum load [kg]	10 (max. 10 per insert)	15 (max. 15 per insert)
Required door width and height for device transportation		
Width [mm]	800	900
Height [mm]	750	750
Noise level	< 70 dB (A)	
Ambient temperature	>+4 °C	

Tab. 6: Device data

3.2 REQUIREMENTS FOR THE LOCATION FOR INSTALLATION



CAUTION!

Material damage from incorrect conditions of use!

Incorrect operation of the device and faulty device.

- ▶ Ambient temperatures: $>4\text{ }^{\circ}\text{C}$
- ▶ Environment free from toxic or explosive gases or substances.
- ▶ When operating outdoors: Protected from rain, storms, lightning strike and wind.
- ▶ We recommend setting up underneath an exhaust hood.
- ▶ Do not install any equipment which is sensitive to steam or temperature (e.g. furniture, shelves etc.), or any electronic devices (e.g. screens, TVs etc.) directly above the Backmaster. Steam may escape from the exhaust air pipes when the door is opened.
- ▶ Do not install any external attachments or extensions to the exhaust air pipe except for original Eloma equipment (mixed kits, condensation hoods).

3.2.1 MINIMUM CLEARANCE FOR OPERATION AND MAINTENANCE WORK

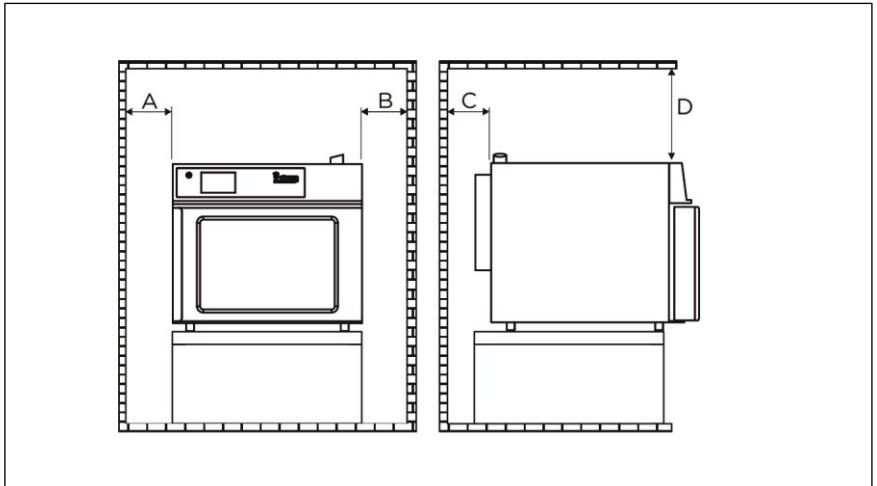

Fig. 1: Minimum clearances for Backmaster EB 30^{MT} / EB 30 XL^{MT}

Dimension	Clearance [mm]
A	Side with operating panel to the wall
	Minimum clearance > 50
B	Side without operating panel to the wall
	Minimum clearance > 50
C	Rear of the baking device to the wall
	Minimum clearance > 50
D	Top edge of the exhaust air pipe to the ceiling
	Exhaust hood provided by the operating company > 50
	Device with Multi Eco condensation hood, assembled > 500
	Without exhaust hood provided by the operating company > 1000
Baking devices to other combi steamers, baking ovens, heating cabinets etc. > 50 mm, make sure there is sufficient ventilation	

Tab. 7: Minimum clearances



WARNING!

Fire damage as a result of fat explosion!

- ▶ The vapours from the Backmaster must never come into contact with hot fat/oil.

3.3 DATA FOR DEVICE CONNECTION



INFORMATION:

- ▶ Adhere to the data on the type plate.

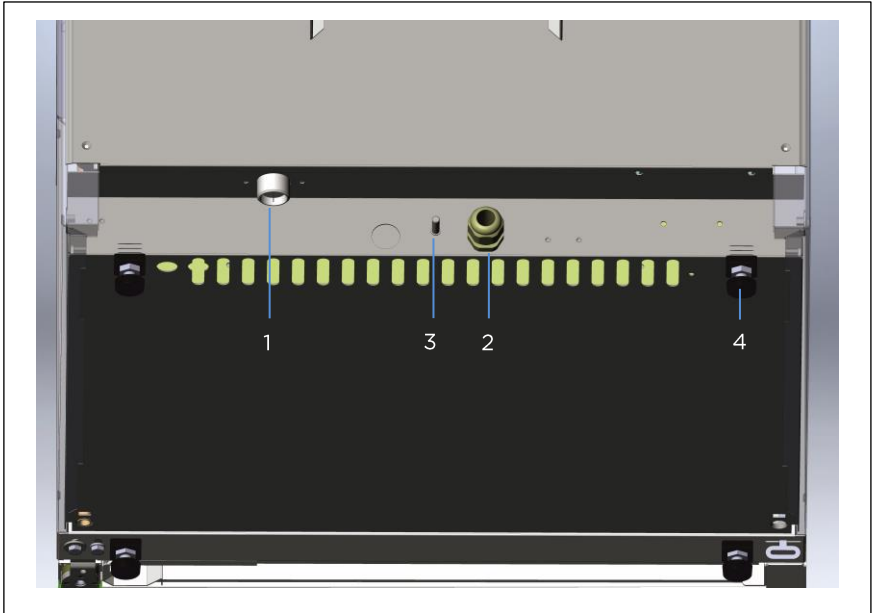

Fig. 2: Device connection

- 1 Soft water connection
- 2 Electrical cable connection
- 3 Equipotential bonding connection
- 4 Feet, adjustable

3.4 CONNECTION DATA

3.4.1 WATER CONNECTION

Data	EB 30 ^{MT}	EB 30 XL ^{MT}
Mobile with fresh water tank	Option	
Water type	Drinking water	
Fresh water tank	2 l	
Fixed water connection		
Water type	Drinking water	
Water connection	1 x G 3/4A	
Connection type	1/2 hose with 3/4 union screw connection and flat seal (flexible, pressure resistant and approved as per EN 13618)	
Connection pressure [bar]/[kPa]	2 - 6 / 200 - 600	
Volumetric flow rate (pressure-related)		
Soft water [l/h]	15	
Max. volumetric flow rate [l/h]	30	

Tab. 8: Specifications for water connection



INFORMATION ON THE FIXED WATER CONNECTION:

- ▶ The indicated values for drinking water depend on the pressure and correspond to pressure of 4 bar / 400 kPa.
- ▶ For a total hardness of $\geq 4^\circ\text{dH}$ and above we recommend supplying the drinking water connection with treated water. The composition of the water determines the type of water treatment you select. Please obtain information from your local water supply company on the water quality and water hardness before installation.
- ▶ Before establishing the water connection, flush the operating company's water line.
- ▶ The operating company must provide an easily accessible water shut-off valve for each individual device.
- ▶ Only corrosion-resistant lines must be used downstream of a water softener.

3.4.2 ELECTRICAL CONNECTION



INFORMATION:

- ▶ The following applies for all electrical connections: Use a residual-current circuit breaker.
- ▶ For the connection of the Backmaster we recommend a circuit breaker with cut-off characteristic D because of the components in the device (transformers, capacitors etc.).

Data	EB 30 ^{MT}	EB 30 XL ^{MT}
Connection cable [kW]	3.6	5.9
Voltage	1 NAC 230 V	3 NAC 400 V
Fuse protection [A]	1 x 16	3 x 16
Heat emission		
Latent [MJ/h]	2.33	3.82
Sensible [MJ/h]	1.56	2.55

Tab. 9: Data for electrical connection

4 TRANSPORTING AND UNPACKING THE BACKMASTER



INFORMATION:

- ▶ Check the device for external damage after delivery.
- ▶ In case of damage to the device:
 - Do not install the device.
 - Contact an Eloma service partner.

4.1 TRANSPORTING THE BACKMASTER WITH A LIFT TRUCK



INFORMATION:

- ▶ Use a lift truck to transport, lift and lower the device.
- ▶ Be aware of the total weight.
- ▶ Secure the device to prevent it from toppling over during transportation.
- ▶ Only ever transport the device on a pallet.
- ▶ Adhere to the required minimum height and width for doors, passageways etc.

4.2 UNPACKING THE DEVICE AND ACCESSORIES

1. Remove the cartons, packaging material, accessories and documents from the baking chamber.
2. Dispose of the packaging in accordance with the local regulations and environmental requirements.
3. It is imperative to remove any protective films from the device and accessories.
4. Remove residue with glass cleaner.

NOTE!

Material damage to the device!

Protective film burning in.

- ▶ Do not commission the device with the protective film.

5 SETTING UP THE BACKMASTER



WARNING!

Injury due to uncontrolled movements of the Backmaster!

Crushing of feet and hands.

- ▶ The device must be lifted from the pallet by at least two persons.
- ▶ Beware of your fingers when setting the device down.

NOTE!

"Caution: Hot fluids in insert containers"!

If the access height reaches or exceeds 1.60 m, attach the enclosed warning sticker (see Fig. 3) to the front of the device at a height of 1.60 m above the access level, in a clearly visible place, after installing the device at a height.



Fig. 3: Sticker, Caution! Hot fluids in insert containers (included with delivery)

5.1 GENERAL SET-UP INSTRUCTIONS (SUMMARY)

1. Adhere to the local regulations and generally valid regulations.
2. When setting up in the vicinity of heat-sensitive substances or substances which are at risk from fire, adhere to the fire safety regulations.
3. Make sure that the installation location meets the requirements.
4. Make sure that the minimum clearances are observed.
5. Secure the device to prevent it from toppling, falling or being displaced.
6. Remove the transport securing device from inside the baking chamber.
7. Check the device for external damage. Do not connect the device if you suspect damage.
8. Make sure that the air baffle is locked in place.
9. Make sure that there are no flammable materials above the device.
10. Make sure that the supply air opening and ventilation slats are unobstructed and not covered.
11. Keep the area between the device feet free in order to make sure that there is sufficient ventilation underneath the device.
12. Make sure that the set-up surface can support the weight of the device.



INFORMATION:

- ▶ We recommend that you set up on original Eloma base frames or base cabinets. When setting up on work surfaces, you must make sure that they are stable and have sufficient load bearing capacity. Take into account the weight of the devices.

13. Secure devices with castors using the foot brake. Devices with castors or on base frames with castors must also be secured mechanically to the power supply (e.g. chain, cable) to prevent them from shifting.
14. Always align the device horizontally.



INFORMATION:

- ▶ Even out any minor unevenness as necessary using the height-adjustable device feet.

15. Make sure that no items of furniture or electronic devices (e.g. screens, computers etc.), that are sensitive to steam or heat, are installed above the device, because steam may escape from the exhaust air pipe when the device is opened during operation.
16. Eloma Backmasters are not built-in devices!

NOTE!

Insufficient ventilation!

Control failures and moisture precipitation caused by hot accumulation and reduced condensation performance of the condensation hood.

- ▶ The device can only be set up in situations similar to built-in devices, for example, in shelves or cabinets, with a condensation hood.
- ▶ Additionally, sufficient air conveyance must be ensured to allow an air flow of 660 m³/h via the condensation hood.

17. Make sure that stacked devices and Backmasters on high tables and frames are secured to the wall.
18. For mixed baking stations adhere to the additional separate installation instructions.

6 CONNECTING THE BACKMASTER

6.1 SUPPLY WATER CONNECTION



CAUTION!

Damage from improper connection!

Water damage.

- ▶ The local and regional regulations for the water connection have to be adhered to.
- ▶ Have the water connections made by authorised service companies.
- ▶ Adhere to the connection markings on the baking device.
- ▶ Adhere to the data on the type plate.



CAUTION!

Material damage due to installation of incorrect water treatment systems!

Damage to the glass pane, baking chamber and parts of the device.

- ▶ Do not install sodium ion exchangers.
- ▶ Do not install systems with silicate batching.
- ▶ Do not install systems based on electromagnetic fields.
- ▶ Regular maintenance of any type of water treatment systems is absolutely imperative. Consequential damage to the Eloma devices due to insufficient maintenance will render the warranty cover null and void.

Limit values for the supply water

Parameter	Permitted limit value
Total hardness	$\leq 3^\circ \text{dH}$
pH value	7.0 - 8.5
Conductance	$\leq 90 \mu\text{S/cm}$
Cl^-	$< 60 \text{ mg/l}$
SO_4	$< 100 \text{ mg/l}$
SiO_4	$< 10 \text{ mg/l}$
Fe	$< 0.05 \text{ mg/l}$
Mn	$< 0.05 \text{ mg/l}$
Cu	$< 0.05 \text{ mg/l}$
Cl_2	$< 0.1 \text{ mg/l}$

Tab. 10: Limit values for the supply water

NOTE!

- ▶ If the total water hardness is $\geq 5^\circ \text{dH}$, at least one hydrogen ion exchanger has to be installed upstream of the device-side water connection. Partial desalination filters with integrated particle and activated carbon filters and a bypass are the permitted filter systems for our devices. Brita, for instance, supply adequate filter systems.
- ▶ In case of water contamination with sand, iron particles or suspended matter a fine filter with a filter fineness of 5 - 15 μm has to be installed upstream.
- ▶ If the water is chlorinated Cl_2 with more than 0.1 mg/l (equivalent of 0.1 ppm), an activated carbon filter has to be installed upstream. A combined particle filter with activated carbon cover both requirements.



INFORMATION ON REVERSE OSMOSIS:

- ▶ Reverse osmosis systems can in general represent an alternative to full and partial desalination using filter systems. Reverse osmosis systems remove almost all hardening constituents and non-hardening minerals from the water.
- ▶ If there is a chlorine concentration Cl^- of more than 60 mg/l (equivalent of 60 ppm) and/or a silicate concentration (SiO_4) $\geq 10 \text{ mg/l}$, a reverse osmosis system has to be provided on the device-side water connection because of the considerably increased risk of corrosion.
- ▶ For reverse osmosis systems make sure that a residual hardness with a conductance of 10 $\mu\text{S/cm}$ is adhered to in order to prevent damage.

6.2 ELECTRICAL CONNECTION



DANGER!

Electric shock due to improper installation!

- ▶ Make sure that the electrical connection is only established by an authorised electrical installation technician.
- ▶ Adhere to the local and regional laws, directives and regulations of the contracted energy supply company.
- ▶ Integrate the baking device into the equipotential bonding system.



DANGER!

Electric shock due to damaged cables!

- ▶ Have a damaged electrical cable replaced immediately. Do not connect the baking device with a damaged electrical cable.
- ▶ Lay cables so that they are protected from damage during operation.
- ▶ Do not touch exposed cable ends.

NOTE!

- ▶ Do not connect the Backmaster to the mains immediately after it has been brought into a warm room from a cold environment, otherwise there is a risk of condensation inside the device (e.g. electrical control system).
- ▶ The device must only be installed by authorised staff (approved electrical installation technician, service specialist etc.).
- ▶ An effective electrical separator with a contact opening of at least 3 mm has to be installed upstream on the installation side near to the device.
- ▶ The devices are generally equipped with a mains cable (without plug connector).
- ▶ If the device is equipped with a plug connector, the plug device must be accessible after setting up the device.
- ▶ Adhere to the data on the type plate.

6.3 DOOR LATCH, EMERGENCY RELEASE

The Backmaster is equipped with an automatic door latch.

- ▶ The door on the Backmaster is closed by the operator with a "gentle push".
- ▶ The door is opened automatically at the end of the program in accordance with the setting in the service menu.
- ▶ The door can be opened during and after operation by selecting the "Open door" field on the display screen.
- ▶ There is a risk of burns when the door opens automatically after the baking process.
- ▶ In case of a fault, power failure or if the devices are without power the door can simply be opened mechanically.
- ▶ There is an emergency release underneath the door on the side where the handle is.
- ▶ Push the emergency release down. The door springs open.

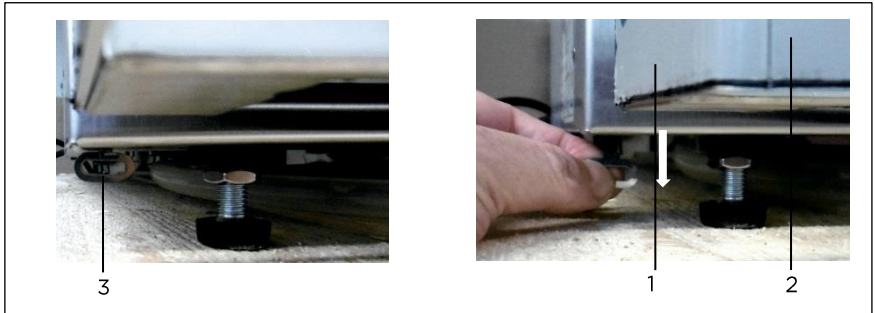

Fig. 4: Door latch emergency release

- 1 Handle
- 2 Door
- 3 Emergency release

7 DISPOSAL AND ENVIRONMENTAL PROTECTION

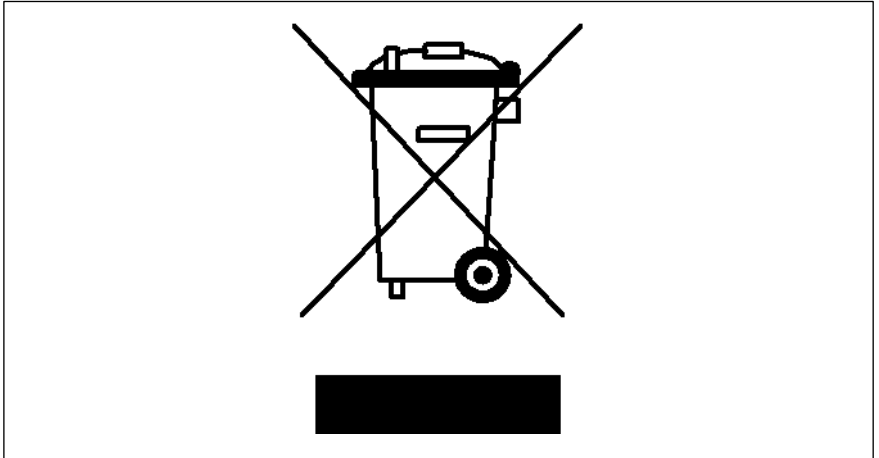

Fig. 5: Disposal symbol

Strict adherence to the legal rules, quality standards and regulations, and a high environmental awareness form the basic standards for development, production and servicing of the in-store baking ovens on our premises. However, as well as valuable recyclable materials, these devices with electronic circuits also contain harmful substances which were necessary for their function and safety.

- ▶ Therefore, you must not dispose of the device with the residual waste as these substances may be harmful to your health and the environment.
- ▶ Dispose of it in accordance with the local regulations for used devices.
- ▶ If you have any questions, contact the responsible authorities (e.g. authority for waste management).

8 APPENDICES

8.1 DIMENSIONAL DRAWINGS

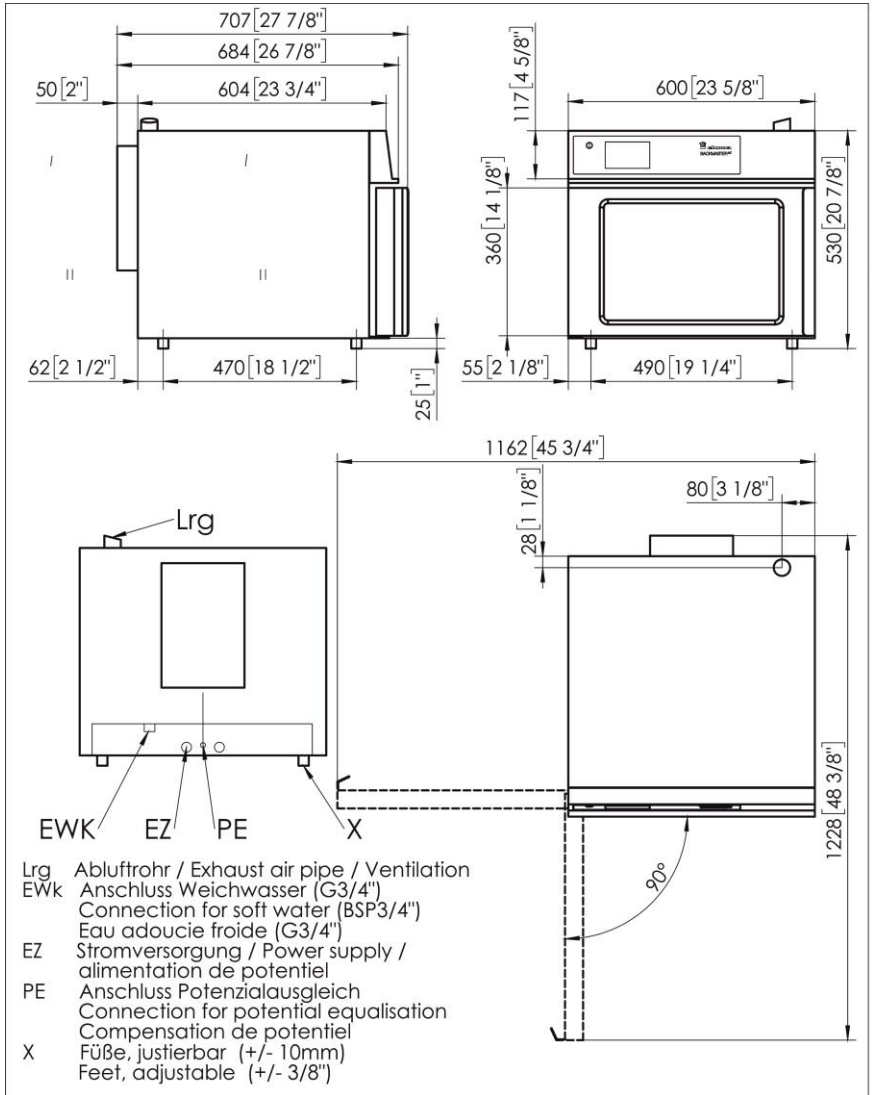

Fig. 6: Backmaster EB 30^{MT}, left-hinged door

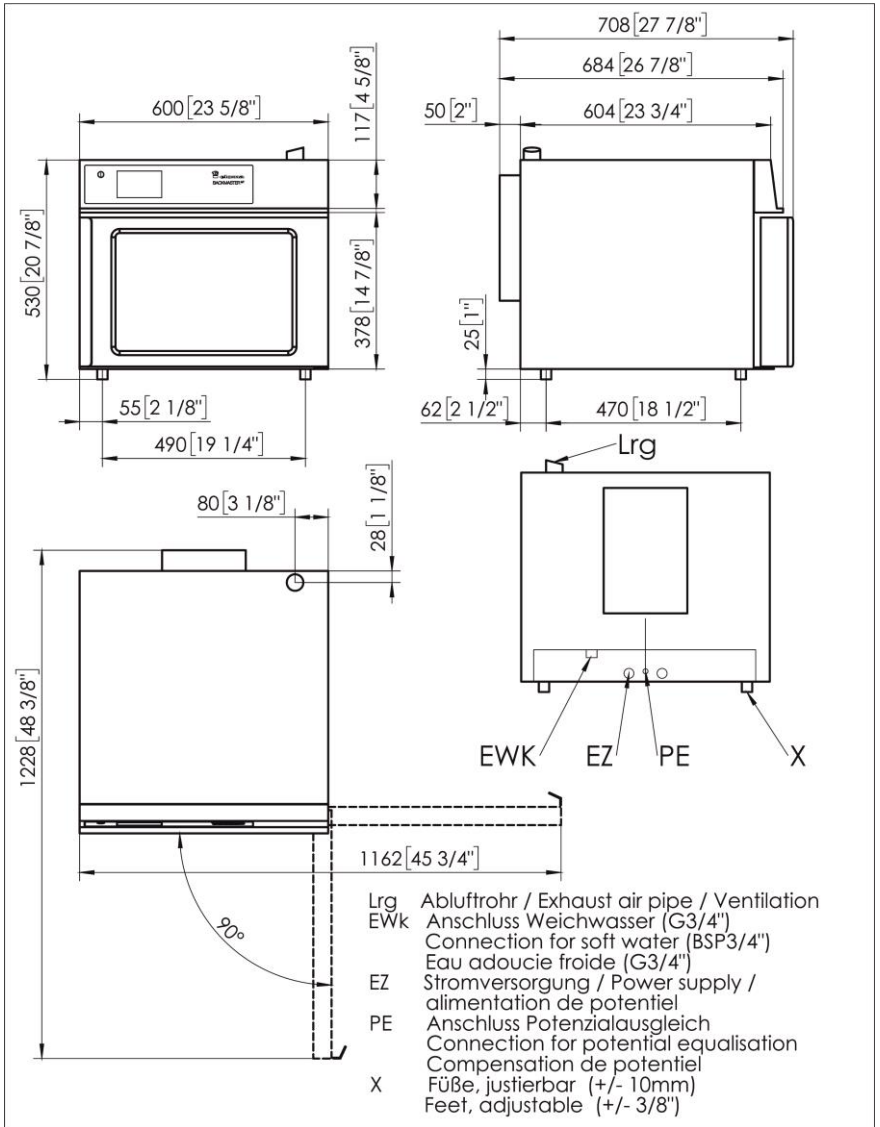

Fig. 7: Backmaster EB 30^{MT}, right-hinged door

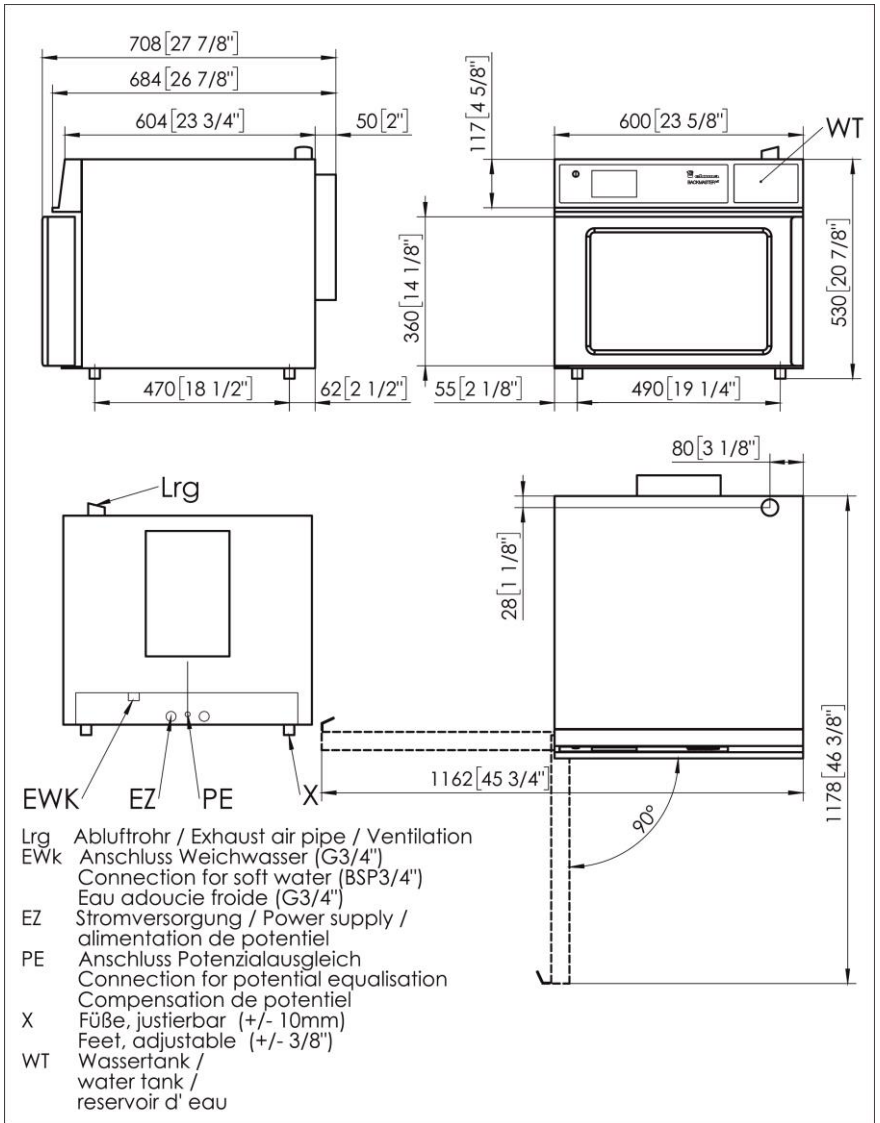

Fig. 8: Backmaster EB 30^{MT} with water tank, left-hinged door

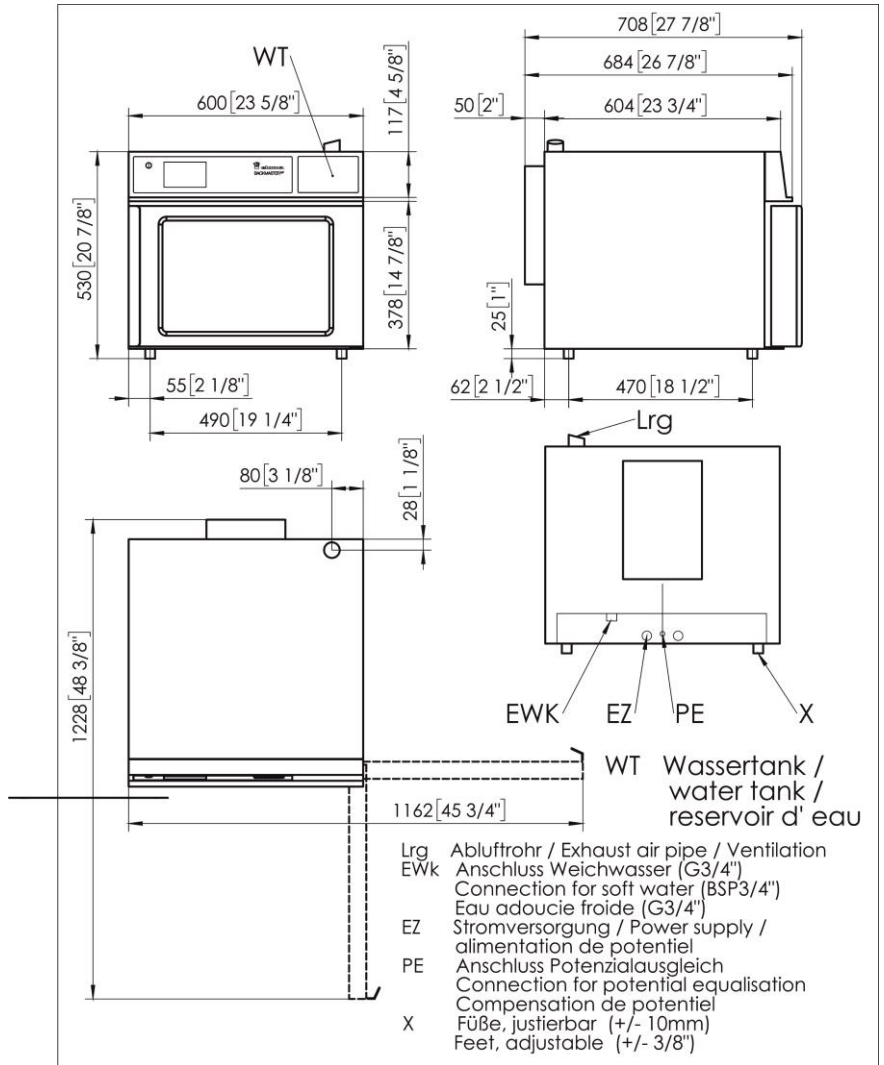

Fig. 9: Backmaster EB 30^{MT} with water tank, right-hinged door

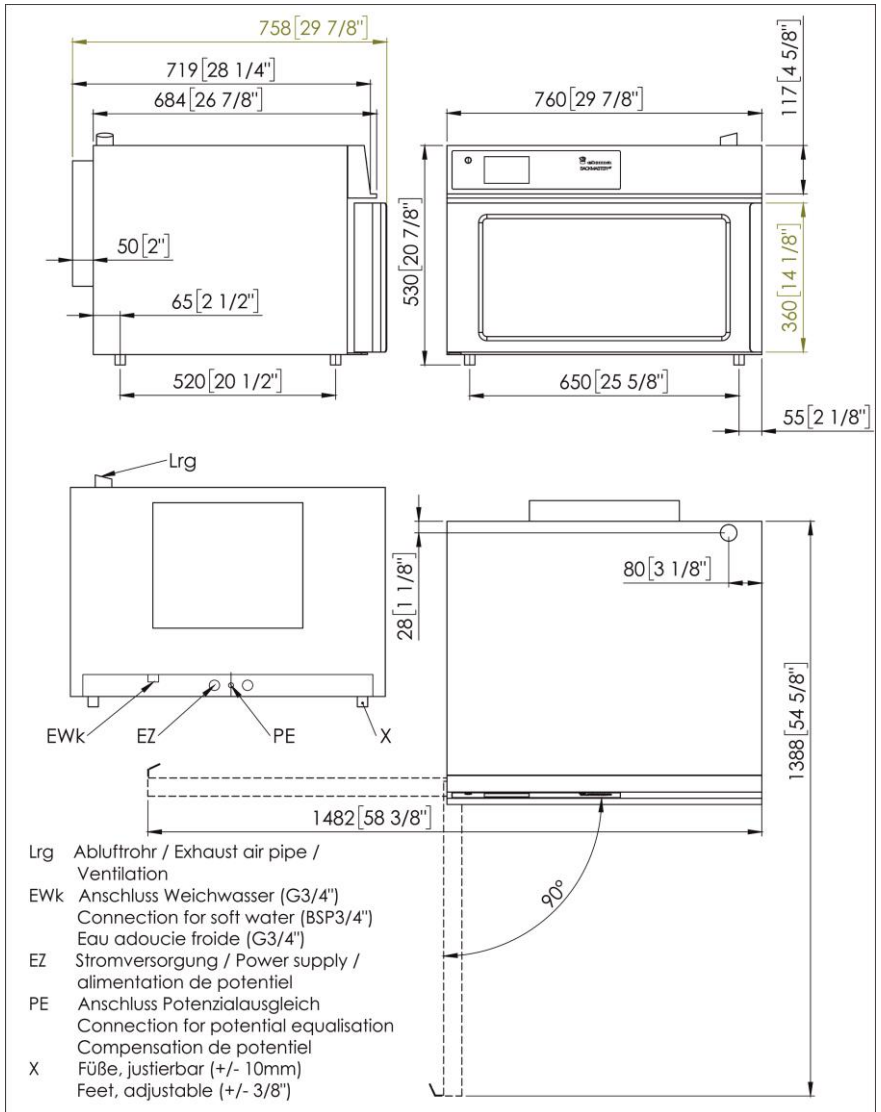

Fig. 10: Backmaster EB 30 XL^{MT}, left-hinged door

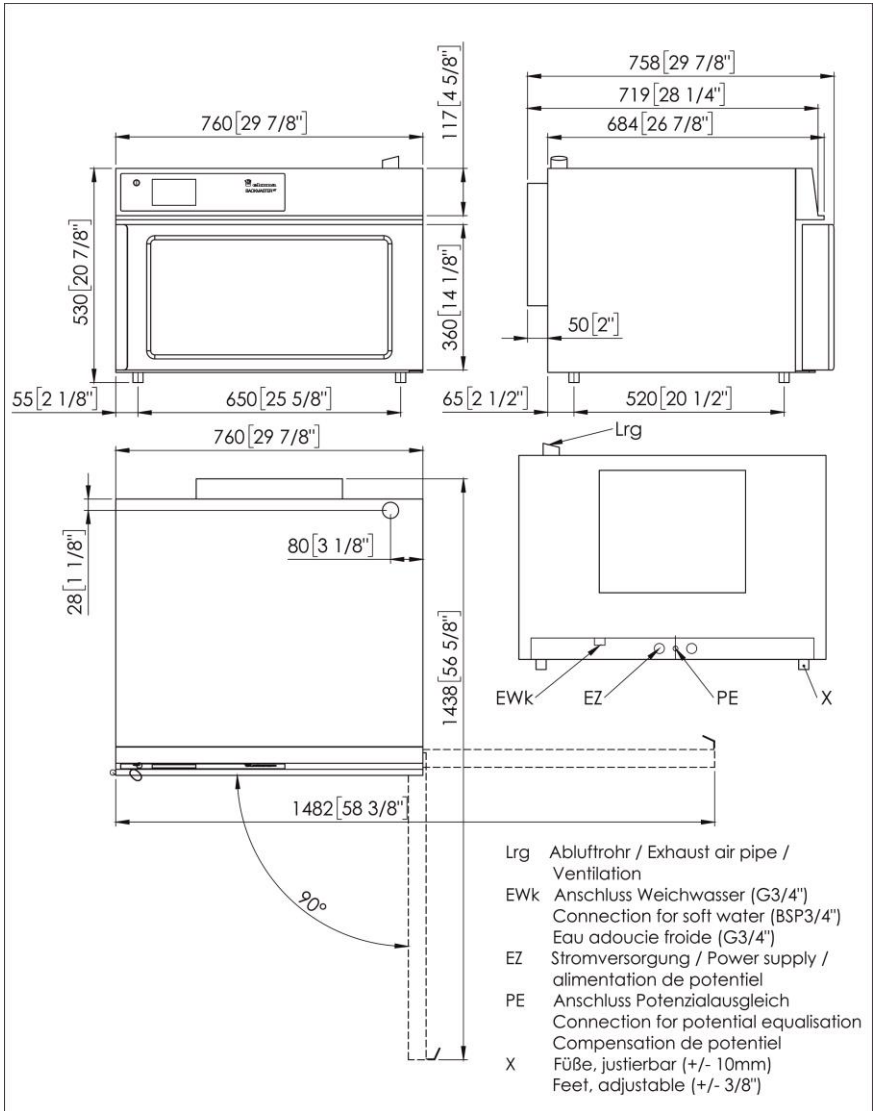

Fig. 11: Backmaster EB 30 XL^{MT}, right-hinged door

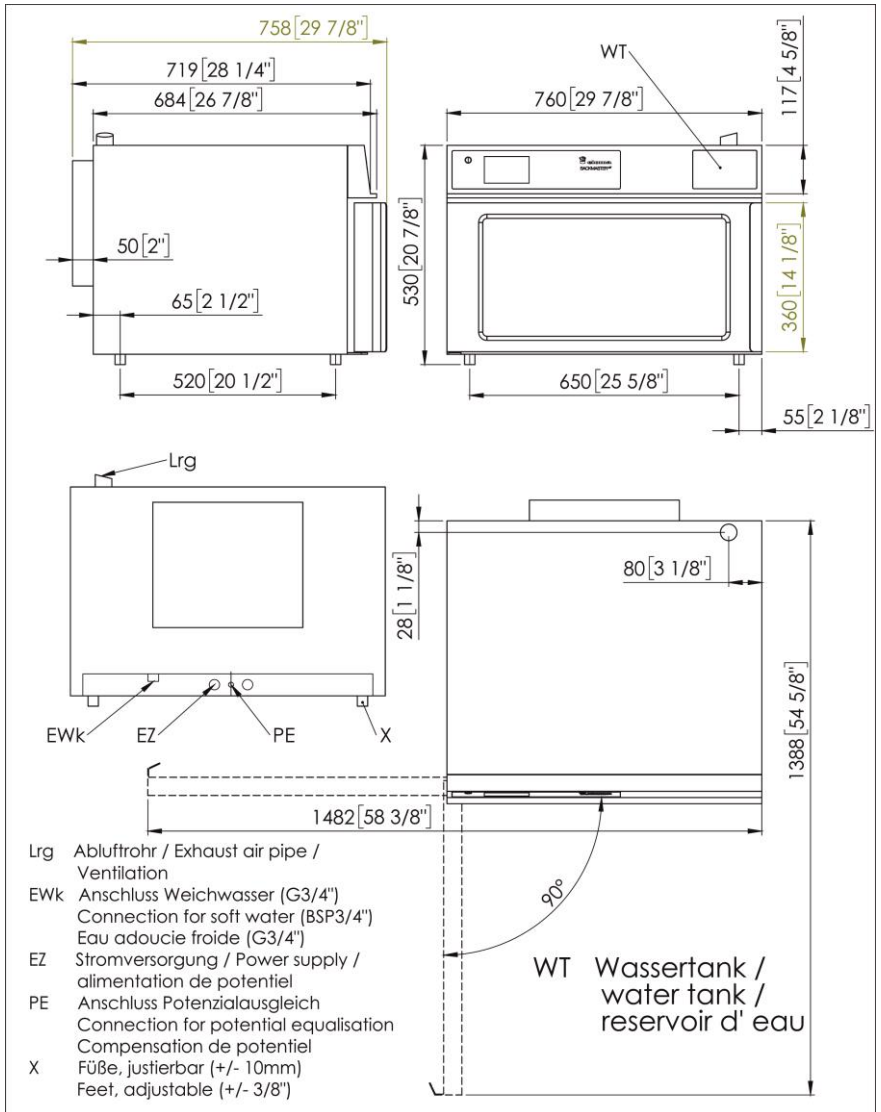

Fig. 12: Backmaster EB 30 XL^{MT} with water tank, left-hinged door

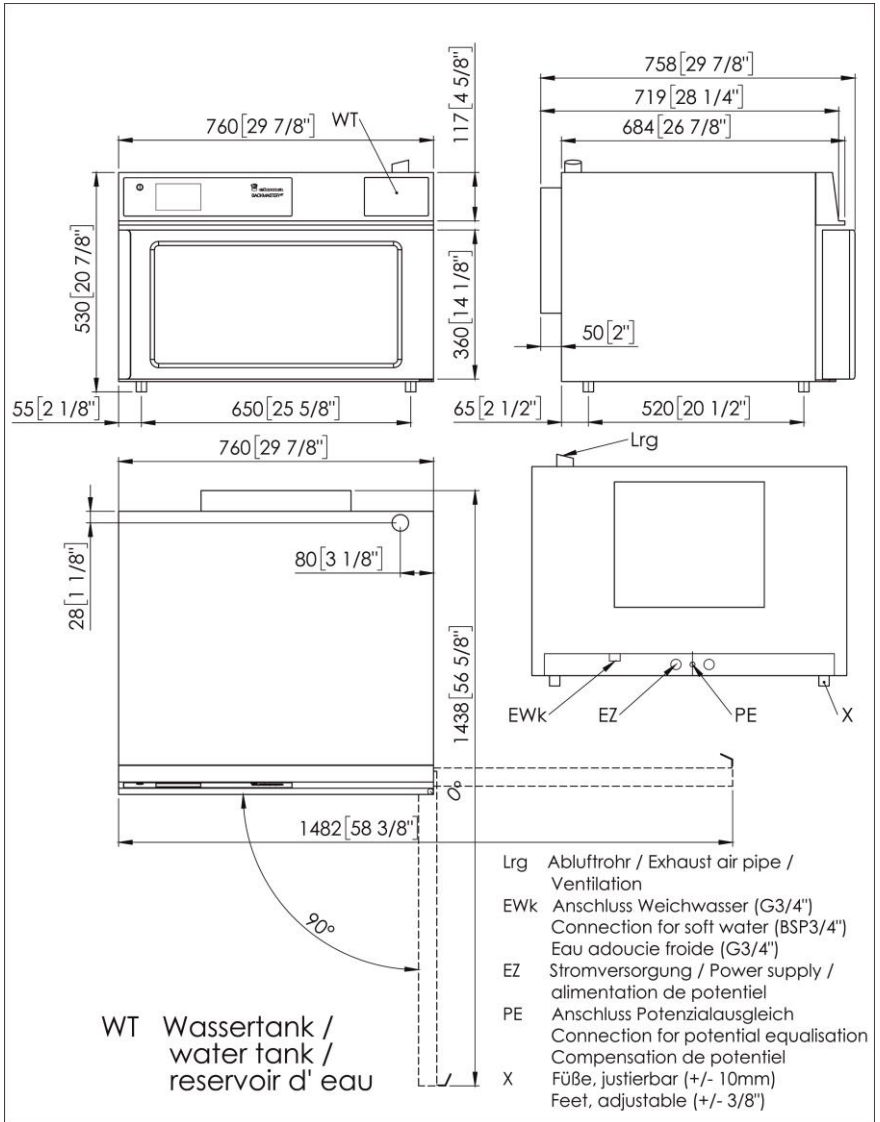

Fig. 13: Backmaster EB 30 XL MT with water tank, right-hinged door

9 MAINTENANCE COMMENTS / NOTES

WE AT ELOMA WILL BE HAPPY TO HELP YOU WITH
ANY QUESTIONS RELATING TO OUR PRODUCTS

CUSTOMER SERVICE

T. +49 8141 395-188
F. +49 8141 395-164
sales@eloma.com

APPLICATION ADVICE

T. +49 8141 395-150
applications@eloma.com

TECHNICAL SERVICE

T. +49 35023 63-888
F. +49 8141 359-156
service@eloma.com



Eloma GmbH
An ALI Group Company



The Spirit of Excellence